



FRAKO EMA 1496  
Communications Guide



## Contents

|          |  |           |
|----------|--|-----------|
| <b>1</b> | <b>FRAKO EMA 1496 Digital Meter Modbus Protocol implementation</b> | <b>3</b>  |
| 1.1      | Modbus Protocol Overview   | 3         |
| 1.2      | Input Registers  | 3         |
| 1.2.1    | EMA 1496 Input Registers   | 4         |
| 1.3      | Modbus Protocol Holding Registers and Digital meter set up         | 5         |
| 1.3.1    | EMA 1496 MODBUS Protocol Holding Register Parameters               | 6         |
| <b>2</b> | <b>RS485 General Information</b>                                   | <b>9</b>  |
| 2.1      | Half Duplex  | 9         |
| 2.2      | Connecting the Instruments   | 9         |
| 2.3      | A and B terminals  | 10        |
| 2.4      | Troubleshooting  | 10        |
| <b>3</b> | <b>MODBUS Protocol General Information</b>                         | <b>12</b> |
| 3.1      | MODBUS Protocol Message Format                                     | 12        |
| 3.2      | Serial Transmission Modes  | 13        |
| 3.3      | MODBUS Protocol Message Timing (RTU Mode)                          | 14        |
| 3.4      | How Characters are Transmitted Serially                            | 14        |
| 3.5      | Error Checking Methods   | 15        |
| 3.5.1    | Parity Checking  | 15        |
| 3.5.2    | CRC Checking   | 15        |
| 3.6      | Function Codes   | 16        |
| 3.7      | IEEE floating point format   | 16        |
| 3.8      | MODBUS Protocol Commands supported                                 | 18        |
| 3.8.1    | Read Input Registers   | 18        |
| 3.9      | Holding Registers  | 18        |
| 3.9.1    | Read Holding Registers   | 18        |
| 3.9.2    | Write Holding Registers  | 19        |
| 3.10     | Exception Response   | 20        |
| 3.11     | Exception Codes  | 20        |
| 3.11.1   | Table of Exception Codes   | 20        |
| 3.12     | Diagnostics  | 20        |
| <b>4</b> | <b>RS485 Implementation of Johnson Controls Metasys</b>            | <b>22</b> |
| 4.1      | Application details  | 22        |
| 4.1.1    | Metasys release requirements                                       | 22        |
| 4.1.2    | Design considerations  | 22        |
| 4.2      | FRAKO EMA 1496 Digital meter METASYS N2 Point Mapping table        | 23        |

# 1 FRAKO EMA 1496 Digital Meter Modbus Protocol implementation

## 1.1 Modbus Protocol Overview

This section provides basic information for interfacing the FRAKO EMA 1496 to a Modbus Protocol network. If background information or more details of the FRAKO implementation is required please refer to further sections of this document.

The EMA 1496 offers the option of an RS485 communication facility for direct connection to SCADA or other communications systems using the Modbus Protocol RTU slave protocol. The Modbus Protocol establishes the format for the master's query by placing into it the device address, a function code defining the requested action, any data to be sent, and an error checking field. The slave's response message is also constructed using Modbus Protocol. It contains fields confirming the action taken, any data to be returned, and an error-checking field. If an error occurs in receipt of the message, the EMA 1496 will make no response. If the EMA 1496 is unable to perform the requested action, it will construct an error message and send it as the response.

The electrical interface is 2-wire RS485, via 3 screw terminals. Connection should be made using twisted pair screened cable (Typically 22 gauge Belden 8761 or equivalent). All "A" and "B" connections are daisy chained together. The screens should also be connected to the "Gnd" terminal. To avoid the possibility of loop currents, an Earth connection should be made at only one point on the network.

Line topology may or may not require terminating loads depending on the type and length of cable used. Loop (ring) topology does not require any termination load.

The impedance of the termination load should match the impedance of the cable and be at both ends of the line. The cable should be terminated at each end with a 120 ohm (0.25 Watt min.) resistor.

A total maximum length of 3900 feet (1200 metres) is allowed for the RS485 network. A maximum of 32 electrical nodes can be connected, including the controller.

The address of each device can be set to any value between 1 and 247. Broadcast mode (address 0) is not supported.

The maximum latency time this device is 60ms i.e. this is the amount of time that can pass before the first response character is output. The supervisory programme must allow this period of time to elapse before assuming that the FRAKO EMA 1496 is not going to respond.

The format for each byte in RTU mode is:

|                    |   |
|--------------------|---|
| Coding System:     | 8-bit per byte  |
| Data Format:       | 4 bytes (2 registers) per parameter.<br>Floating point format ( to IEEE 754)<br>Most significant register first (Default). The default may be changed if required -<br>See Holding Register "Register Order" parameter. |
| Error Check Field: | 2 byte Cyclical Redundancy Check (CRC)  |
| Framing:           | 1 start bit<br>8 data bits, least significant bit sent first<br>1 bit for even/odd parity (or no parity)<br>1 stop bit if parity is used; 1 or 2 bits if no parity  |

### Data Coding

All data values are transferred as 32 bit IEEE 754 floating point numbers, (input and output) therefore each FRAKO digital meter value is transferred using two MODBUS Protocol registers. All register read requests and data write requests must specify an even number of registers. Attempts to read/write an odd number of registers prompt the EMA 1496 digital meter to return a MODBUS Protocol exception message. However, for compatibility with some SCADA systems, the EMA 1496 will respond to any single input or holding register read with an instrument type specific value.

The EMA 1496 can transfer a maximum of 40 values in a single transaction, therefore the maximum number of registers requestable is 80. Exceeding this limit prompts the EMA 1496 to generate an exception response.

Data Transmission speed is selectable between 2400, 4800, 9600, 19200 and 38400 baud.

## 1.2 Input Registers

Input registers are used to indicate the present values of the measured and calculated electrical quantities. Each parameter is held in two consecutive 16 bit registers. The following table details the 3X register address, and the values of the address bytes within the message. A tick (√) in the column indicates that the parameter is valid for the particular wiring system. Any parameter with a cross (X) will return the value Zero. Each parameter is held in the 3X registers. Modbus Protocol Function Code 04 is used to access all parameters.



| Address (Register) | Parameter Number | EMA 1496 Input Register Parameter  |       | Modbus Protocol Start Address Hex |         | 3 | 3 | 1 |
|--------------------|------------------|------------------------------------|-------|-----------------------------------|---------|---|---|---|
|                    |                  | Description                        | Units | Hi Byte                           | Lo Byte | Ø | Ø | Ø |
|                    |                  |                                    |       |                                   |         | 4 | 3 | 2 |
|                    |                  |                                    |       |                                   |         | W | W | W |
| 30103              | 52               | Maximum total system VA demand.    | VA    | 00                                | 66      | ✓ | ✓ | ✓ |
| 30105              | 53               | Neutral current demand.            | Amps  | 00                                | 68      | ✓ | ✗ | ✗ |
| 30107              | 54               | Maximum neutral current demand.    | Amps  | 00                                | 6A      | ✓ | ✗ | ✗ |
| 30201              | 101              | Line 1 to Line 2 volts.            | Volts | 00                                | C8      | ✓ | ✓ | ✗ |
| 30203              | 102              | Line 2 to Line 3 volts.            | Volts | 00                                | CA      | ✓ | ✓ | ✗ |
| 30205              | 103              | Line 3 to Line 1 volts.            | Volts | 00                                | CC      | ✓ | ✓ | ✗ |
| 30207              | 104              | Average line to line volts.        | Volts | 00                                | CE      | ✓ | ✓ | ✗ |
| 30225              | 113              | Neutral current.                   | Amps  | 00                                | E0      | ✓ | ✗ | ✗ |
| 30235              | 118              | Phase 1 L/N volts THD              | %     | 00                                | EA      | ✓ | ✗ | ✓ |
| 30237              | 119              | Phase 2 L/N volts THD              | %     | 00                                | EC      | ✓ | ✗ | ✗ |
| 30239              | 120              | Phase 3 L/N volts THD              | %     | 00                                | EE      | ✓ | ✗ | ✗ |
| 30241              | 121              | Phase 1 Current THD                | %     | 00                                | F0      | ✓ | ✓ | ✓ |
| 30243              | 122              | Phase 2 Current THD                | %     | 00                                | F2      | ✓ | ✓ | ✗ |
| 30245              | 123              | Phase 3 Current THD                | %     | 00                                | F4      | ✓ | ✓ | ✗ |
| 30249              | 125              | Average line to neutral volts THD. | %     | 00                                | F8      | ✓ | ✗ | ✓ |
| 30251              | 126              | Average line current THD.          | %     | 00                                | FA      | ✓ | ✓ | ✓ |
| 30255              | 128              | -Total system power factor (5).    | Cos Ø | 00                                | FE      | ✓ | ✓ | ✓ |
| 30259              | 130              | Phase 1 current demand.            | Amps  | 01                                | 02      | ✓ | ✓ | ✓ |
| 30261              | 131              | Phase 2 current demand.            | Amps  | 01                                | 04      | ✓ | ✓ | ✗ |
| 30263              | 132              | Phase 3 current demand.            | Amps  | 01                                | 06      | ✓ | ✓ | ✗ |
| 30265              | 133              | Maximum phase 1 current demand.    | Amps  | 01                                | 08      | ✓ | ✓ | ✓ |
| 30267              | 134              | Maximum phase 2 current demand.    | Amps  | 01                                | 0A      | ✓ | ✓ | ✗ |
| 30269              | 135              | Maximum phase 3 current demand.    | Amps  | 01                                | 0C      | ✓ | ✓ | ✗ |
| 30335              | 168              | Line 1 to line 2 volts THD.        | %     | 01                                | 4E      | ✓ | ✓ | ✗ |
| 30337              | 169              | Line 2 to line 3 volts THD.        | %     | 01                                | 50      | ✓ | ✓ | ✗ |
| 30339              | 170              | Line 3 to line 1 volts THD.        | %     | 01                                | 52      | ✓ | ✓ | ✗ |
| 30341              | 171              | Average line to line volts THD.    | %     | 01                                | 54      | ✓ | ✓ | ✗ |

**Notes:**

1. The power factor has its sign adjusted to indicate the nature of the load. Positive for capacitive and negative for inductive.
2. There is a user option to select either k or M for the energy prefix.
3. The same user option as in 2 above gives a prefix of none or k for Amphours
4. The power sum demand calculation is for import power only
5. The negative total system power factor is a sign inverted version of parameter 32, the magnitude is the same as parameter 32.

**1.3 Modbus Protocol Holding Registers and Digital meter set up**

Holding registers are used to store and display instrument configuration settings. All holding registers not listed in the table below should be considered as reserved for manufacturer use and no attempt should be made to modify their values.

The holding register parameters may be viewed or changed using the Modbus Protocol. Each parameter is held in two consecutive 4X registers. Modbus Protocol Function Code 03 is used to read the parameter and Function Code 16 is used to write. Write to only one parameter per message.

1.3.1 EMA 1496 MODBUS Protocol Holding Register Parameters

| Address (Register) | Parameter Number | Parameter           | Modbus Protocol Start Address Hex |          | Valid range   | Mode |
|--------------------|------------------|---------------------|-----------------------------------|----------|---|------|
|                    |                  |                     | High Byte                         | Low Byte |   |      |
| 40001              | 1                | Demand Time         | 00                                | 00       | Read minutes into first demand calculation. When the Demand Time reaches the Demand Period then the demand values are valid.  | ro   |
| 40003              | 2                | Demand Period       | 00                                | 02       | Write demand period: 0, 5, 8, 10, 15, 20, 30 or 60 minutes, default 60. Setting the period to 0 will cause the "phase # current demand" parameters to show the "phase # current" values, and "Maximum phase # current demand" to show the maximum value of the "phase # current" parameter since last demand reset. | r/w  |
| 40007              | 4                | System Volts        | 00                                | 06       | Read system voltage, VLL for 3P3W, VLN for others.  | ro   |
| 40009              | 5                | System Current      | 00                                | 08       | Write system current, limited to 1 to 9999A. Requires password, see parameter 13  | r/wp |
| 40011              | 6                | System Type         | 00                                | 0A       | Write system type: 3p4w = 3, 3p3w = 2 & 1p2w = 1<br>Requires password, see parameter 13   | r/wp |
| 40013              | 7                | Relay Pulse Width   | 00                                | 0C       | Write relay on period in milliseconds: 60, 100 or 200, default 200.   | r/w  |
| 40015              | 8                | Password Lock       | 00                                | 0E       | Write any value to password lock protected registers.<br>Read password lock status: 0 = locked. 1 = unlocked.<br>Reading will also reset the password timeout back to one minute.   | r/w  |
| 40019              | 10               | Network Parity Stop | 00                                | 12       | Write the network port parity/stop bits for MODBUS Protocol, where: 0 = One stop bit and no parity, default. 1 = One stop bit and even parity. 2 = One stop bit and odd parity. 3 = Two stop bits and no parity.<br>Requires a restart to become effective.   | r/w  |

| Address (Register) | Parameter Number | Parameter           | Modbus Protocol Start Address Hex |          | Valid range  | Mode |
|--------------------|------------------|---------------------|-----------------------------------|----------|--|------|
|                    |                  |                     | High Byte                         | Low Byte |  |      |
| 40021              | 11               | Network Node        | 00                                | 14       | Write the network port node address: 1 to 247 for MODBUS Protocol, default 1. Requires a restart to become effective. Note, both the MODBUS Protocol and Johnson Controls node addresses can be changed via the display setup menus. | r/w  |
| 40023              | 12               | Pulse Divisor       | 00                                | 16       | Write pulse divisor index: n = 2 to 6 in Wh/IO <sup>n</sup> , default 3.   | r/w  |
| 40025              | 13               | Password            | 00                                | 18       | Write password for access to protected registers. Read zero. Reading will also reset the password timeout back to one minute. Default password is 0000.  | r/w  |
| 40029              | 15               | Network Baud Rate   | 00                                | 1C       | Write the network port baud rate for MODBUS Protocol, where:<br>0 = 2400 baud.<br>1 = 4800 baud.<br>2 = 9600 baud, default.<br>3 = 19200 baud.<br>4 = 38400 baud.<br>Requires a restart to become effective                          | r/w  |
| 40031              | 16               | Energy Units Prefix | 00                                | 1E       | Write the units prefix for energy output values.<br>0 = k, e.g. kWh, default. But Ah for ampere hours.<br>1 = M, e.g. MWh. But kAh for ampere hours.   | r/w  |
| 40037              | 19               | System Power        | 00                                | 24       | Read the total system power, e.g. for 3p4w returns System Volts x System Amps x 3.   | ro   |
| 40041              | 21               | Register Order      | 00                                | 28       | Write the value 2141 in the required register order.   | r/w  |
| 40043              | 22               | Serial Number Hi    | 00                                | 2A       | Read the first product serial number.  | ro   |
| 40045              | 23               | Serial Number Lo    | 00                                | 2C       | Read the second product serial number.   | ro   |
| 40087              | 44               | Relay1 Energy Type  | 00                                | 56       | Write MODBUS Protocol input parameter for pulse relay 1:<br>0 = relay off, 37 = Import Wh or 39 = Import VARh, default 37.   | r/w  |
| 40089              | 45               | Relay2 Energy Type  | 00                                | 58       | MODBUS Protocol input parameter for pulse relay 2:<br>0 = relay off, 37 = Import Wh or 39 = Import VARh, default 37.   | r/w  |

| Address<br>(Register) | Parameter<br>Number | Parameter         | Modbus Protocol<br>Start Address<br>Hex |             | Valid range   | Mode |
|-----------------------|---------------------|-------------------|---|-------------|---|------|
|                       |                     |                   | High<br>Byte                            | Low<br>Byte |   |      |
| 40217                 | 109                 | Reset Logged Data | 00                                      | D8          | Write code to reset data group.<br>Code 1 for Energy.<br>Code 2 for Demand Maximums.<br>Code 3 for Demand Maximums and Demand Time. | r/w  |



## 2 RS485 General Information

RS485 or EIA (Electronic Industries Association) RS485 is a balanced line, half-duplex transmission system allowing transmission distances of up to 1.2 km. The following table summarises the RS-485 Standard:

| PARAMETER                                 |  |
|---|--|
| Mode of Operation                         | Differential                                       |
| Number of Drivers and Receivers           | 32 Drivers,<br>32 Receivers                        |
| Maximum Cable Length                      | 1200 m   |
| Maximum Data Rate                         | 10 M baud  |
| Maximum Common Mode Voltage               | 12 V to -7 V                                       |
| Minimum Driver Output Levels (Loaded)     | +/- 1.5 V  |
| Minimum Driver Output Levels (Unloaded)   | +/- 6 V  |
| Drive Load                                | Minimum 60 ohms                                    |
| Driver Output Short Circuit Current Limit | 150 mA to Gnd,<br>250 mA to 12 V<br>250 mA to -7 V |
| Minimum Receiver Input Resistance         | 12 kohms   |
| Receiver Sensitivity                      | +/- 200 mV   |

Further information relating to RS485 may be obtained from either the EIA or the various RS485 device manufacturers, for example Texas Instruments or Maxim Semiconductors. This list is not exhaustive.

### 2.1 Half Duplex

Half duplex is a system in which one or more transmitters (talkers) can communicate with one or more receivers (listeners) with only one transmitter being active at any one time. For example, a "conversation" is started by asking a question, the person who has asked the question will then listen until he gets an answer or until he decides that the individual who was asked the question is not going to reply.

In a 485 network the "master" will start the "conversation" with a "query" addressed to a specific "slave", the "master" will then listen for the "slave's" response. If the "slave" does not respond within a pre-defined period, (set by control software in the "master"), the "master" will abandon the "conversation".

### 2.2 Connecting the Instruments

If connecting an RS485 network to a PC use caution if contemplating the use of an RS232 to 485 converter together with a USB to RS485 adapter. Consider either an RS232 to RS485 converter, connected directly to a suitable RS232 jack on the PC, or use a USB to RS485 converter or, for desktop PCs a suitable plug in RS485 card. *(Many 232:485 converters draw power from the RS232 socket. If using a USB to RS232 adapter, the adapter may not have enough power available to run the 232:485 converter.)*

Screened twisted pair cable should be used. For longer cable runs or noisier environments, use of a cable specifically designed for RS485 may be necessary to achieve optimum performance. All "A" terminals should be connected together using one conductor of the twisted pair cable, all "B" terminals should be connected together using the other conductor in the pair. The cable screen should be connected to the "Gnd" terminals.

A Belden 9841 (Single pair) or 9842 (Two pair) or similar cable with a characteristic impedance of 120 ohms is recommended. The cable should be terminated at each end with a 120 ohm, quarter watt (or greater) resistor. Note: Diagram shows wiring topology only. Always follow terminal identification on FRAKO Digital meter product label.

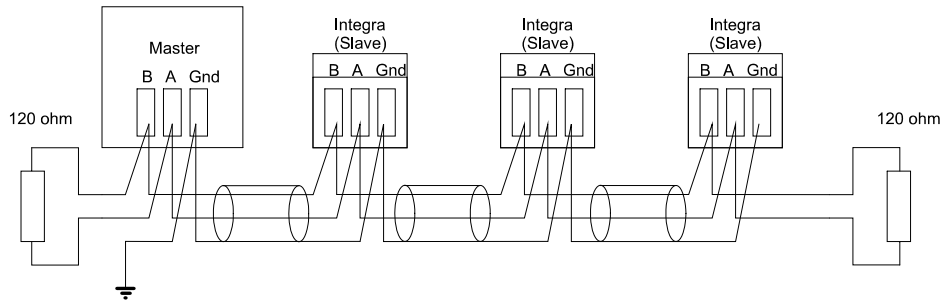

There must be no more than two wires connected to each terminal, this ensures that a “Daisy Chain or “straight line” configuration is used. A “Star” or a network with “Stubs (Tees)” is not recommended as reflections within the cable may result in data corruption.

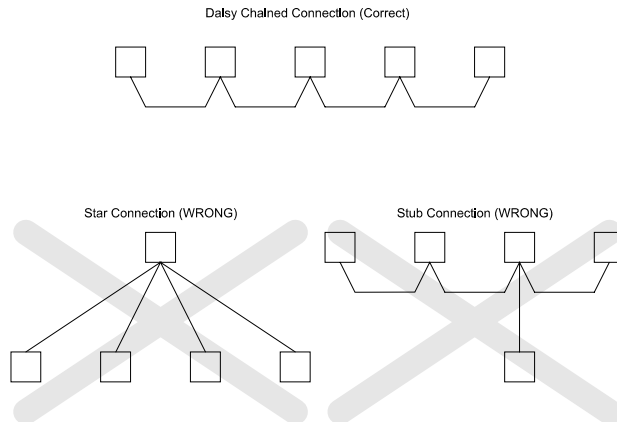

### 2.3 A and B terminals

The A and B connections to the EMA 1496 can be identified by the signals present on them whilst there is activity on the RS485 bus:

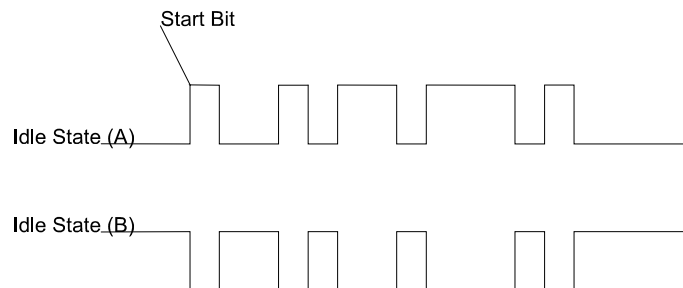

### 2.4 Troubleshooting

- Start with a simple network, one master and one slave. With the FRAKO EMA 1496 digital meter this is easily achieved as the network can be left intact whilst individual instruments are disconnected by removing the RS485 connection from the rear of the instrument.
- Check that the network is connected together correctly. That is all of the “A’s” are connected together, and all of the “B’s” are connected together, and also that all of the “Gnd’s” are connected together.
- Confirm that the data “transmitted” onto the RS485 is not echoed back to the PC on the RS232 lines. (This facility is sometimes a link option within the converter). Many PC based packages seem to not perform well when they receive an echo of the message they are transmitting. SpecView and PCView (PC software) with a RS232 to RS485 converter are believed to include this feature.
- Confirm that the Address of the instrument is the same as the “master” is expecting.
- If the “network” operates with one instrument but not more than one check that each instrument has a unique address.
- Each request for data must be restricted to 40 parameters or less. Violating this requirement will impact the performance of the instrument and may result in a response time in excess of the specification.

- Check that the MODBUS Protocol mode (RTU or ASCII) and serial parameters (baud rate, number of data bits, number of stop bits and parity) are the same for all devices on the network.
- Check that the “master” is requesting floating-point variables (pairs of registers placed on floating point boundaries) and is not “splitting” floating point variables.
- Check that the floating-point byte order expected by the “master” is the same as that used by the FRAKO EMA 1496 Digital meter. (PCView and Citect packages can use a number of formats including that supported by the EMA 1496).
- If possible obtain a second RS232 to RS485 converter and connect it between the RS485 bus and an additional PC equipped with a software package, which can display the data on the bus. Check for the existence of valid requests.

### 3 MODBUS Protocol General Information

Communication on a MODBUS Protocol Network is initiated (started) by a “Master” sending a query to a “Slave”. The “Slave”, which is constantly monitoring the network for queries addressed to it, will respond by performing the requested action and sending a response back to the “Master”. Only the “Master” can initiate a query.

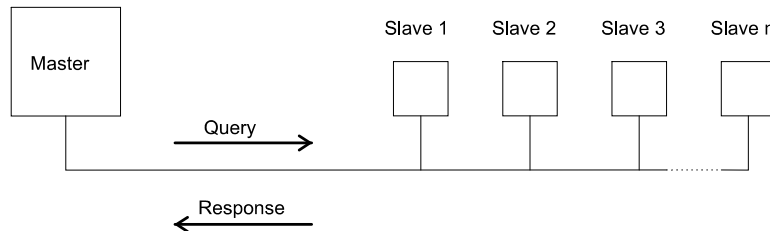

In the MODBUS Protocol the master can address individual slaves, or, using a special “Broadcast” address, can initiate a broadcast message to all slaves. The device does not support the broadcast address.

#### 3.1 MODBUS Protocol Message Format

The MODBUS Protocol defines the format for the master’s query and the slave’s response.

The query contains the device (or broadcast) address, a function code defining the requested action, any data to be sent, and an error-checking field.

The response contains fields confirming the action taken, any data to be returned, and an error-checking field. If an error occurred in receipt of the message then the message is ignored, if the slave is unable to perform the requested action, then it will construct an error message and send it as its response.

The MODBUS Protocol functions used by the FRAKO EMA 1496 Digital meter copy 16 bit register values between master and slaves. However, the data used by the EMA 1496 is in 32 bit IEEE 754 floating point format. Thus each instrument parameter is conceptually held in two adjacent MODBUS Protocol registers.

#### Query

The following example illustrates a request for a single floating point parameter i.e. two 16-bit Modbus Protocol Registers.

| First<br>Byte    |                  |                          |                          |                                |                                |                        | Last<br>Byte           |
|------------------|------------------|--------------------------|--------------------------|--------------------------------|--------------------------------|------------------------|------------------------|
| Slave<br>Address | Function<br>Code | Start<br>Address<br>(Hi) | Start<br>Address<br>(Lo) | Number<br>of<br>Points<br>(Hi) | Number<br>of<br>Points<br>(Lo) | Error<br>Check<br>(Lo) | Error<br>Check<br>(Hi) |

**Slave Address:** 8-bit value representing the slave being addressed (1 to 247), 0 is reserved for the broadcast address. The EMA 1496 Digital meter does not support the broadcast address.

**Function Code:** 8-bit value telling the addressed slave what action is to be performed. (3, 4, 8 or 16 are valid for the EMA 1496)

**Start Address (Hi):** The top (most significant) eight bits of a 16-bit number specifying the start address of the data being requested.

**Start Address (Lo):** The bottom (least significant) eight bits of a 16-bit number specifying the start address of the data being requested. As registers are used in pairs and start at zero, then this must be an even number.

**Number of Points (Hi):** The top (most significant) eight bits of a 16-bit number specifying the number of registers being requested.

**Number of Points (Lo):** The bottom (least significant) eight bits of a 16-bit number specifying the number of registers being requested. As registers are used in pairs, then this must be an even number.

**Error Check (Lo):** The bottom (least significant) eight bits of a 16-bit number representing the error check value.

**Error Check (Hi):** The top (most significant) eight bits of a 16-bit number representing the error check value.

**Response**

The example illustrates the normal response to a request for a single floating point parameter i.e. two 16-bit Modbus Protocol Registers.

| First Byte    |               |            |                     |                     |                      |                      | Last Byte        |                  |
|---------------|---------------|------------|---------------------|---------------------|----------------------|----------------------|------------------|------------------|
| Slave Address | Function Code | Byte Count | First Register (Hi) | First Register (Lo) | Second Register (Hi) | Second Register (Lo) | Error Check (Lo) | Error Check (Hi) |

- Slave Address: 8-bit value representing the address of slave that is responding.
- Function Code: 8-bit value which, when a copy of the function code in the query, indicates that the slave recognised the query and has responded. (See also Exception Response).
- Byte Count: 8-bit value indicating the number of data bytes contained within this response
- First Register (Hi)\*: The top (most significant) eight bits of a 16-bit number representing the first register requested in the query.
- First Register (Lo)\*: The bottom (least significant) eight bits of a 16-bit number representing the first register requested in the query.
- Second Register (Hi)\*: The top (most significant) eight bits of a 16-bit number representing the second register requested in the query.
- Second Register (Lo)\*: The bottom (least significant) eight bits of a 16-bit number representing the second register requested in the query.
- Error Check (Lo): The bottom (least significant) eight bits of a 16-bit number representing the error check value.
- Error Check (Hi): The top (most significant) eight bits of a 16-bit number representing the error check value.

\* These four bytes together give the value of the floating point parameter requested.

**Exception Response**

If an error is detected in the content of the query (excluding parity errors and Error Check mismatch), then an error response (called an exception response), will be sent to the master. The exception response is identified by the function code being a copy of the query function code but with the most-significant bit set. The data contained in an exception response is a single byte error code.

| First Byte    |               | Last Byte  |                  |                  |
|---------------|---------------|------------|------------------|------------------|
| Slave Address | Function Code | Error Code | Error Check (Lo) | Error Check (Hi) |

- Slave Address: 8-bit value representing the address of slave that is responding.
- Function Code: 8 bit value which is the function code in the query OR'ed with 80 hex, indicating that the slave either does not recognise the query or could not carry out the action requested.
- Error Code: 8-bit value indicating the nature of the exception detected. (See "Table Of Exception Codes" later).
- Error Check (Lo): The bottom (least significant) eight bits of a 16-bit number representing the error check value.
- Error Check (Hi): The top (most significant) eight bits of a 16-bit number representing the error check value.

**3.2 Serial Transmission Modes**

There are two MODBUS Protocol serial transmission modes, ASCII and RTU. The FRAKO EMA 1496 Digital meter does not support the ASCII mode.

In RTU (Remote Terminal Unit) mode, each 8-bit byte is used in the full binary range and is not limited to ASCII characters as in ASCII Mode. The greater data density allows better data throughput for the same baud rate, however each message must be transmitted in a continuous stream. This is very unlikely to be a problem for modern communications equipment.

The format for each byte in RTU mode is:

|                                      |  |
|--------------------------------------|--|
| Coding System:                       | Full 8-bit binary per byte. In this document, the value of each byte will be shown as two hexadecimal characters each in the range 0-9 or A-F. |
| Line Protocol:                       | 1 start bit, followed by the 8 data bits. The 8 data bits are sent with least significant bit first.   |
| User Option Of Parity And Stop Bits: | No Parity and 2 Stop Bits<br>No Parity and 1 Stop Bit<br>Even Parity and 1 Stop Bit.<br>Odd Parity and 1 Stop Bit.                             |
| User Option of Baud Rate:            | 4800 ; 9600 ; 19200 ; 38400 (older FRAKO Digital meters do not support 38400 but do offer 2400 instead)  |

The baud rate, parity and stop bits must be selected to match the master's settings.

### 3.3 MODBUS Protocol Message Timing (RTU Mode)

A MODBUS Protocol message has defined beginning and ending points. The receiving devices recognises the start of the message, reads the "Slave Address" to determine if they are being addressed and knowing when the message is completed they can use the Error Check bytes and parity bits to confirm the integrity of the message. If the Error Check or parity fails then the message is discarded.

In RTU mode, messages starts with a silent interval of at least 3.5 character times.

The first byte of a message is then transmitted, the device address.

Master and slave devices monitor the network continuously, including during the 'silent' intervals. When the first byte (the address byte) is received, each device checks it to find out if it is the addressed device. If the device determines that it is the one being addressed it records the whole message and acts accordingly, if it is not being addressed it continues monitoring for the next message.

Following the last transmitted byte, a silent interval of at least 3.5 character times marks the end of the message. A new message can begin after this interval.

The entire message must be transmitted as a continuous stream. If a silent interval of more than 1.5 character times occurs before completion of the message, the receiving device flushes the incomplete message and assumes that the next byte will be the address byte of a new message.

Similarly, if a new message begins earlier than 3.5 character times following a previous message, the receiving device may consider it a continuation of the previous message. This will result in an error, as the value in the final CRC field will not be valid for the combined messages.

### 3.4 How Characters are Transmitted Serially

When messages are transmitted on standard MODBUS Protocol serial networks each byte is sent in this order (left to right):

Transmit Character = Start Bit + Data Byte + Parity Bit + 1 Stop Bit (11 bits total):

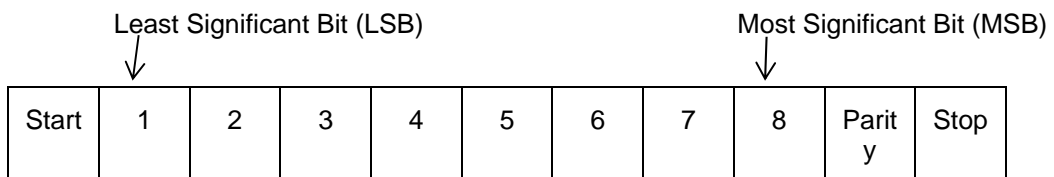

Transmit Character = Start Bit + Data Byte + 2 Stop Bits (11 bits total):

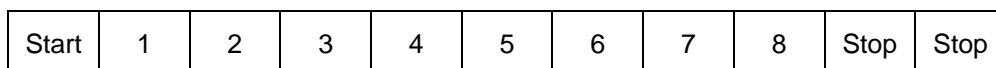

FRAKO Digital meters additionally support No parity, One stop bit.

Transmit Character = Start Bit + Data Byte + 1 Stop Bit (10 bits total):

|       |   |   |   |   |   |   |   |   |      |
|-------|---|---|---|---|---|---|---|---|------|
| Start | 1 | 2 | 3 | 4 | 5 | 6 | 7 | 8 | Stop |
|-------|---|---|---|---|---|---|---|---|------|

The master is configured by the user to wait for a predetermined timeout interval. The master will wait for this period of time before deciding that the slave is not going to respond and that the transaction should be aborted. Care must be taken when determining the timeout period from both the master and the slaves' specifications. The slave may define the 'response time' as being the period from the receipt of the last bit of the query to the transmission of the first bit of the response. The master may define the 'response time' as period between transmitting the first bit of the query to the receipt of the last bit of the response. It can be seen that message transmission time, which is a function of the baud rate, must be included in the timeout calculation.

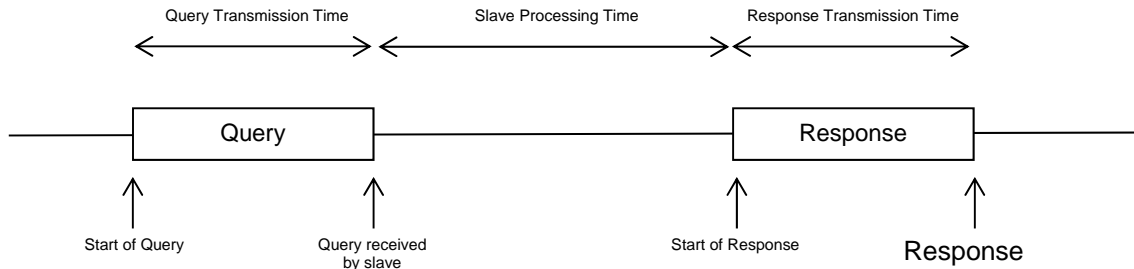

### 3.5 Error Checking Methods

Standard MODBUS Protocol serial networks use two error checking processes, the error check bytes mentioned above check message integrity whilst Parity checking (even or odd) can be applied to each byte in the message.

#### 3.5.1 Parity Checking

If parity checking is enabled – by selecting either Even or Odd Parity - the quantity of “1’s” will be counted in the data portion of each transmit character. The parity bit will then be set to a 0 or 1 to result in an Even or Odd total of “1’s”.

Note that parity checking can only detect an error if an odd number of bits are picked up or dropped in a transmit character during transmission, if for example two 1’s are corrupted to 0’s the parity check will not find the error.

If No Parity checking is specified, no parity bit is transmitted and no parity check can be made. Also, if No Parity checking is specified and one stop bit is selected the transmit character is effectively shortened by one bit.

#### 3.5.2 CRC Checking

The error check bytes of the MODBUS Protocol messages contain a Cyclical Redundancy Check (CRC) value that is used to check the content of the entire message. The error check bytes must always be present to comply with the MODBUS Protocol, there is no option to disable it.

The error check bytes represent a 16-bit binary value, calculated by the transmitting device. The receiving device must recalculate the CRC during receipt of the message and compare the calculated value to the value received in the error check bytes. If the two values are not equal, the message should be discarded. The error check calculation is started by first pre-loading a 16-bit register to all 1’s (i.e. Hex (FFFF)) each successive 8-bit byte of the message is applied to the current contents of the register. Note: only the eight bits of data in each transmit character are used for generating the CRC, start bits, stop bits and the parity bit, if one is used, are not included in the error check bytes.

During generation of the error check bytes, each 8-bit message byte is exclusive OR’ed with the lower half of the 16 bit register. The register is then shifted eight times in the direction of the least significant bit (LSB), with a zero filled into the most significant bit (MSB) position. After each shift the LSB prior to the shift is extracted and examined. If the LSB was a 1, the register is then exclusive OR’ed with a pre-set, fixed value. If the LSB was a 0, no exclusive OR takes place.

This process is repeated until all eight shifts have been performed. After the last shift, the next 8-bit message byte is exclusive OR’ed with the lower half of the 16 bit register, and the process repeated. The final contents of the register, after all the bytes of the message have been applied, is the error check value. In the following pseudo code “ErrorWord” is a 16-bit value representing the error check values.

```

BEGIN
  ErrorWord = Hex (FFFF)
  FOR Each byte in message
    ErrorWord = ErrorWord XOR byte in message
    FOR Each bit in byte
      LSB = ErrorWord AND Hex (0001)
      IF LSB = 1 THEN ErrorWord = ErrorWord – 1
      ErrorWord = ErrorWord / 2
      IF LSB = 1 THEN ErrorWord = ErrorWord XOR Hex (A001)
    NEXT bit in byte
  NEXT Byte in message
END

```

### 3.6 Function Codes

The function code part of a MODBUS Protocol message defines the action to be taken by the slave. The The EMA 1496 Digital meter supports the following function codes:

| Code | MODBUS Protocol name       | Description  |
|------|----------------------------|--|
| 03   | Read Holding Registers     | Read the contents of read/write location (4X references)                                   |
| 04   | Read Input Registers       | Read the contents of read only location (3X references)                                    |
| 08   | Diagnostics                | Only sub-function zero is supported. This returns the data element of the query unchanged. |
| 16   | Pre-set Multiple Registers | Set the contents of read/write location (4X references)                                    |

### 3.7 IEEE floating point format

The MODBUS Protocol defines 16 bit “Registers” for the data variables. A 16-bit number would prove too restrictive, for energy parameters for example, as the maximum range of a 16-bit number is 65535. However, there are a number of approaches that have been adopted to overcome this restriction. The FRAKO EMA 1496 Digital meter uses two consecutive registers to represent a floating-point number, effectively expanding the range to +/- 1x10<sup>37</sup>. The values produced by the EMA 1496 can be used directly without any requirement to “scale” the values, for example, the units for the voltage parameters are volts, the units for the power parameters are watts etc.

What is a floating point Number?

A floating-point number is a number with two parts, a mantissa and an exponent and is written in the form 1.234 x 10<sup>5</sup>. The mantissa (1.234 in this example) must have the decimal point moved to the right with the number of places determined by the exponent (5 places in this example) i.e. 1.234x 10<sup>5</sup> = 123400. If the exponent is negative the decimal point is moved to the left.

What is an IEEE 754 format floating-point number?

An IEEE 754 floating point number is the binary equivalent of the decimal floating-point number shown above. The major difference being that the most significant bit of the mantissa is always arranged to be 1 and is thus not needed in the representation of the number. The process by which the most significant bit is arranged to be 1 is called normalisation, the mantissa is thus referred to as a “normal mantissa”. During normalisation the bits in the mantissa are shifted to the left whilst the exponent is decremented until the most significant bit of the mantissa is one. In the special case where the number is zero both mantissa and exponent are zero.



The bits in an IEEE 754 format have the following significance:

|                          |                          |                          |                          |
|--------------------------|--------------------------|--------------------------|--------------------------|
| Data Hi Reg,<br>Hi Byte. | Data Hi Reg,<br>Lo Byte. | Data Lo Reg,<br>Hi Byte. | Data Lo Reg,<br>Lo Byte. |
| SEEE<br>EEEE             | EMMM<br>MMMM             | MMMM<br>MMMM             | MMMM<br>MMMM             |

Where:

- S represents the sign bit where 1 is negative and 0 is positive
- E is the 8-bit exponent with an offset of 127 i.e. an exponent of zero is represented by 127, an exponent of 1 by 128 etc.
- M is the 23-bit normal mantissa. The 24th bit is always 1 and, therefore, is not stored.

Using the above format the floating point number 240.5 is represented as 43708000 hex:

|                         |                         |                         |                         |
|-------------------------|-------------------------|-------------------------|-------------------------|
| Data Hi Reg,<br>Hi Byte | Data Hi Reg,<br>Lo Byte | Data Lo Reg,<br>Hi Byte | Data Lo Reg,<br>Lo Byte |
| 43                      | 70                      | 80                      | 00                      |

The following example demonstrates how to convert IEEE 754 floating-point numbers from their hexadecimal form to decimal form. For this example, we will use the value for 240.5 shown above. Note that the floating-point storage representation is not an intuitive format. To convert this value to decimal, the bits should be separated as specified in the floating-point number storage format table shown above. For example:

|                         |                         |                         |                         |
|-------------------------|-------------------------|-------------------------|-------------------------|
| Data Hi Reg,<br>Hi Byte | Data Hi Reg,<br>Lo Byte | Data Lo Reg,<br>Hi Byte | Data Lo Reg,<br>Lo Byte |
| 0100 0011               | 0111 0000               | 1000 0000               | 0000 0000               |

From this you can determine the following information.

- The sign bit is 0, indicating a positive number.
- The exponent value is 10000110 binary or 134 decimal. Subtracting 127 from 134 leaves 7, which is the actual exponent.
- The mantissa appears as the binary number 11100001000000000000000

There is an implied binary point at the left of the mantissa that is always preceded by a 1. This bit is not stored in the hexadecimal representation of the floating-point number. Adding 1 and the binary point to the beginning of the mantissa gives the following:

1.11100001000000000000000

Now, we adjust the mantissa for the exponent. A negative exponent moves the binary point to the left. A positive exponent moves the binary point to the right. Because the exponent is 7, the mantissa is adjusted as follows:

11110000.1000000000000000

Finally, we have a binary floating-point number. Binary bits that are to the left of the binary point represent the power of two corresponding to their position. For example, 11110000 represents  $(1 \times 2^7) + (1 \times 2^6) + (1 \times 2^5) + (1 \times 2^4) + (0 \times 2^3) + (0 \times 2^2) + (0 \times 2^1) + (0 \times 2^0) = 240$ .

Binary bits that are to the right of the binary point also represent a power of 2 corresponding to their position. As the digits are to the right of the binary point the powers are negative. For example: .100 represents  $(1 \times 2^{-1}) + (0 \times 2^{-2}) + (0 \times 2^{-3}) + \dots$  which equals 0.5.

Adding these two numbers together and making reference to the sign bit produces the number +240.5.

For each floating point value requested two MODBUS Protocol registers (four bytes) must be requested. The received order and significance of these four bytes for the FRAKO EMA 1496 Digital meter is shown below:

|                         |                         |                         |                         |
|-------------------------|-------------------------|-------------------------|-------------------------|
| Data Hi Reg,<br>Hi Byte | Data Hi Reg,<br>Lo Byte | Data Lo Reg,<br>Hi Byte | Data Lo Reg,<br>Lo Byte |
|-------------------------|-------------------------|-------------------------|-------------------------|

### 3.8 MODBUS Protocol Commands supported

The EMA 1496 supports the “Read Input Register” (3X registers), the “Read Holding Register” (4X registers) and the “Pre-set Multiple Registers” (write 4X registers) commands of the MODBUS Protocol RTU protocol. All values stored and returned are in floating point format to IEEE 754 with the most significant register first.

#### 3.8.1 Read Input Registers

MODBUS Protocol code 04 reads the contents of the 3X registers.

Example

The following query will request ‘Volts 1’ from an instrument with node address 1:

| Field Name            | Example (Hex) |
|-----------------------|---------------|
| Slave Address         | 01            |
| Function              | 04            |
| Starting Address High | 00            |
| Starting Address Low  | 00            |
| Number of Points High | 00            |
| Number of Points Low  | 02            |
| Error Check Low       | 71            |
| Error Check High      | CB            |

**Note:** Data must be requested in register pairs i.e. the “Starting Address” and the “Number of Points” must be even numbers to request a floating point variable. If the “Starting Address” or the “Number of points” is odd then the query will fall in the middle of a floating point variable the product will return an error message. The following response returns the contents of Volts 1 as 230.2. But see also “Exception Response” later.

| Field Name                | Example (Hex) |
|---------------------------|---------------|
| Slave Address             | 01            |
| Function                  | 04            |
| Byte Count                | 04            |
| Data, High Reg, High Byte | 43            |
| Data, High Reg, Low Byte  | 66            |
| Data, Low Reg, High Byte  | 33            |
| Data, Low Reg, Low Byte   | 34            |
| Error Check Low           | 1B            |
| Error Check High          | 38            |

### 3.9 Holding Registers

#### 3.9.1 Read Holding Registers

MODBUS Protocol code 03 reads the contents of the 4X registers.

Example

The following query will request the prevailing ‘Demand Time’:

| Field Name            | Example (Hex) |
|-----------------------|---------------|
| Slave Address         | 01            |
| Function              | 03            |
| Starting Address High | 00            |
| Starting Address Low  | 00            |
| Number of Points High | 00            |
| Number of Points Low  | 02            |
| Error Check Low       | C4            |
| Error Check High      | 0B            |

**Note:** Data must be requested in register pairs i.e. the “Starting Address“ and the “Number of Points“ must be even numbers to request a floating point variable. If the “Starting Address“ or the “Number of points“ is odd then the query will fall in the middle of a floating point variable the product will return an error message.

The following response returns the contents of Demand Time as 1, But see also “Exception Response“ later.

| Field Name                | Example (Hex) |
|---------------------------|---------------|
| Slave Address             | 01            |
| Function                  | 03            |
| Byte Count                | 04            |
| Data, High Reg, High Byte | 3F            |
| Data, High Reg, Low Byte  | 80            |
| Data, Low Reg, High Byte  | 00            |
| Data, Low Reg, Low Byte   | 00            |
| Error Check Low           | F7            |
| Error Check High          | CF            |

### 3.9.2 Write Holding Registers

MODBUS Protocol code 10 (16 decimal) writes the contents of the 4X registers.

Example

The following query will set the Demand Period to 60, which effectively resets the Demand Time:

| Field Name                | Example (Hex) |
|---------------------------|---------------|
| Slave Address             | 01            |
| Function                  | 10            |
| Starting Address High     | 00            |
| Starting Address Low      | 02            |
| Number of Registers High  | 00            |
| Number of Registers Low   | 02            |
| Byte Count                | 04            |
| Data, High Reg, High Byte | 42            |
| Data, High Reg, Low Byte  | 70            |
| Data, Low Reg, High Byte  | 00            |
| Data, Low Reg, Low Byte   | 00            |
| Error Check Low           | 67            |
| Error Check High          | D5            |

**Note:** Data must be written in register pairs i.e. the “Starting Address“ and the “Number of Points“ must be even numbers to write a floating point variable. If the “Starting Address“ or the “Number of points“ is odd then the query will fall in the middle of a floating point variable the product will return an error message. In general only one floating point value can be written per query

The following response indicates that the write has been successful. But see also “Exception Response“ later.

| Field Name               | Example (Hex) |
|--------------------------|---------------|
| Slave Address            | 01            |
| Function                 | 10            |
| Starting Address High    | 00            |
| Starting Address Low     | 02            |
| Number of Registers High | 00            |
| Number of Registers Low  | 02            |
| Error Check Low          | E0            |
| Error Check High         | 08            |

### 3.10 Exception Response

If the slave in the “Write Holding Register” example above, did not support that function then it would have replied with an Exception Response as shown below. The exception function code is the original function code from the query with the MSB set i.e. it has had 80 hex logically ORed with it. The exception code indicates the reason for the exception. The slave will not respond at all if there is an error with the parity or CRC of the query. However, if the slave can not process the query then it will respond with an exception. In this case a code 01, the requested function is not support by this slave.

| Field Name       | Example (Hex) |
|------------------|---------------|
| Slave Address    | 01            |
| Function         | 10 OR 80 = 90 |
| Exception Code   | 01            |
| Error Check Low  | 8D            |
| Error Check High | C0            |

### 3.11 Exception Codes

#### 3.11.1 Table of Exception Codes

The EMA 1496 supports the following function codes:

| Exception Code | MODBUS Protocol name | Description  |
|----------------|----------------------|--|
| 01             | Illegal Function     | The function code is not supported by the product  |
| 02             | Illegal Data Address | Attempt to access an invalid address or an attempt to read or write part of a floating point value |
| 03             | Illegal Data Value   | Attempt to set a floating point variable to an invalid value                                       |
| 05             | Slave Device Failure | An error occurred when the instrument attempted to store an update to it's configuration           |

### 3.12 Diagnostics

MODBUS Protocol code 08 provides a number of diagnostic sub-functions. Only the “Return Query Data” sub-function (sub-function 0) is supported on the FRAKO EMA 1496 Digital meter.

#### Example

The following query will send a diagnostic “return query data” query with the data elements set to Hex(AA) and Hex(55) and will expect these to be returned in the response:

| Field Name        | Example (Hex) |
|-------------------|---------------|
| Slave Address     | 01            |
| Function          | 08            |
| Sub-Function High | 00            |
| Sub-Function Low  | 00            |
| Data Byte 1       | AA            |
| Data Byte 2       | 55            |
| Error Check Low   | 5E            |
| Error Check High  | 94            |

Note: Exactly one register of data (two bytes) must be sent with this function.

The following response indicates the correct reply to the query, i.e. the same bytes as the query.

| Field Name        | Example (Hex) |
|-------------------|---------------|
| Slave Address     | 01            |
| Function          | 08            |
| Sub-Function High | 00            |
| Sub-Function Low  | 00            |
| Data Byte 1       | AA            |
| Data Byte 2       | 55            |
| Error Check Low   | 5E            |
| Error Check High  | 94            |

## 4 RS485 Implementation of Johnson Controls Metasys

These notes briefly explain Metasys and EMA 1496 integration. Use these notes with the Metasys Technical Manual, which provides information on installing and commissioning Metasys N2 Vendor devices.

### 4.1 Application details

The EMA 1496 is an N2 Vendor device that connects directly with the Metasys N2 Bus. This implementation assigns key electrical parameters to ADF points, each with override capability.  
Components requirements

- FRAKO EMA 1496 with RS485 card and N2 port available.
- N2 Bus cable.

#### 4.1.1 Metasys release requirements

- Metasys Software Release 12.04 or later
- NCM-361-8 or Metasys Extended Architecture NAE35,NAE45,NAE55

The EMA 1496 may be compatible with earlier releases of N2 software, but Johnson Controls only supports integration issues on the above.

#### 4.1.2 Design considerations

When integrating the EMA 1496 equipment into a Metasys Network, keep the following considerations in mind.

- Make sure all EMA 1496 equipment is set up, started and running properly before attempting to FRAKOte with the Metasys Network.
- A maximum of 32 devices can be connected to any one NCM N2 Bus segment, or up to 100 devices if repeaters are used.
- From the instrument set-up screen, the Coms option must be set to N2, then the address set to the required value. All port settings will then be set automatically, see below.

|                       |       |
|-----------------------|-------|
| <b>Device Address</b> | 1-255 |
| <b>Port Set-up:</b>   |       |
| <b>Baud Rate</b>      | 9600  |
| <b>Duplex</b>         | Half  |
| <b>Word Length</b>    | 8     |
| <b>Stop Bits</b>      | 1     |
| <b>Parity</b>         | None  |
| <b>Interface</b>      | RS485 |

**4.2 FRAKO EMA 1496 Digital meter METASYS N2 Point Mapping table**

| Name            | Units    | ADFPPoint |
|-----------------|----------|-----------|
| V1              | V        | 1         |
| V2              | V        | 2         |
| V3              | V        | 3         |
| A1              | A        | 4         |
| A2              | A        | 5         |
| A3              | A        | 6         |
| KP1             | kW       | 7         |
| KP2             | kW       | 8         |
| KP3             | kW       | 9         |
| KVA1            | kVA      | 10        |
| KVA2            | kVA      | 11        |
| KVA3            | kVA      | 12        |
| KVAR1           | kVAr     | 13        |
| KVAR2           | kVAr     | 14        |
| KVAR3           | kVAr     | 15        |
| PF1             |          | 16        |
| PF2             |          | 17        |
| PF3             |          | 18        |
| PA1             | Degree   | 19        |
| PA2             | Degree   | 20        |
| PA3             | Degree   | 21        |
| AN              | A        | 22        |
| V12             | V        | 23        |
| V23             | V        | 24        |
| V31             | V        | 25        |
| VLNAV           | V        | 26        |
| AAVG            | A        | 27        |
| ASUM            | A        | 28        |
| VLLAVG          | V        | 29        |
| KPSUM           | kW       | 30        |
| KVASUM          | kVA      | 31        |
| KVARSUM         | kVAr     | 32        |
| PFTOT           |          | 33        |
| PATOT           | Degree   | 34        |
| FREQ            | Hz       | 35        |
| LO_EGY_IMP_POW* | 0.1kWh   | 36        |
| HI_EGY_IMP_POW* | 100MWh   | 37        |
| LO_EGY_EXP_POW* | 0.1kWh   | 38        |
| HI_EGY_EXP_POW* | 100MWh   | 39        |
| LO_EGY_IMP_VAR* | 0.1kVArh | 40        |
| HI_EGY_IMP_VAR* | 100MVArh | 41        |
| LO_EGY_EXP_VAR* | 0.1kVArh | 42        |
| HI_EGY_EXP_VAR* | 100MVArh | 43        |
| LO_EGY_VA*      | 0.1kAh   | 44        |
| HI_EGY_VA*      | 100MVAh  | 45        |
| LO_EGY_AMP*     | 0.1Ah    | 46        |
| HI_EGY_AMP*     | 100kAh   | 47        |
| KPSUM_DMD       | kW       | 48        |
| KPSUM_MAX_DMD   | kW       | 49        |
| KVASUM_DMD      | kVA      | 50        |
| KVASUM_MAX_DMD  | kVA      | 51        |
| A1_DMD          | A        | 52        |

|            |   |    |
|------------|---|----|
| A1_MAX_DMD | A | 53 |
| A2_DMD     | A | 54 |
| A2_MAX_DMD | A | 55 |
| A3_DMD     | A | 56 |
| A3_MAX_DMD | A | 57 |
| AN_DMD     | A | 58 |
| AN_MAX_DMD | A | 59 |
| V1_THD     | % | 60 |
| V2_THD     | % | 61 |
| V3_THD     | % | 62 |
| VLNAVG_THD | % | 63 |
| V12_THD    | % | 64 |
| V23_THD    | % | 65 |
| V31_THD    | % | 66 |
| VLLAVG_THD | % | 67 |
| A1_THD     | % | 68 |
| A2_THD     | % | 69 |
| A3_THD     | % | 70 |
| AAVG_THD   | % | 71 |
| RESET      |   | 72 |

Override RESET with the following values to perform a reset.

| Reset          | OverrideValue |
|----------------|---------------|
| Energy         | 1011          |
| DemandMax      | 1012          |
| DemandTimeBase | 1013          |

\* Units shown are for the k energy prefix, they will be 1000 times larger for the M energy prefix, and 1000 times smaller for the no prefix condition.

Note, ADF points are one-based in the JCI compliance test software but zero-based on the network.









All of the above information, including drawings, illustrations and graphic design, reflects our present understanding and is to the best of our knowledge and belief correct and reliable. Users, however, should independently evaluate the suitability of each product for the desired application. Under no circumstances does this constitute an assurance of any particular quality or performance. Such an assurance is only provided in the context of our product specifications or explicit contractual arrangements. Our liability for these products is set forth in our standard terms and conditions of sale.

FRAKO Kondensatoren- und Anlagenbau GmbH  
*Tscheulinstraße 21a*  
79331 Teningen

Tel: +49 (0) 7641-453-0  
Fax: +49 (0) 7641-453-516  
[www.frako.com](http://www.frako.com)



Kondensatoren- und Anlagenbau GmbH

Tscheulinstr. 21a · 79331 Teningen · Germany  
Tel. +49-7641-453-0 · Fax +49-7641-453-535  
<http://www.frako.com> · E-Mail: [info@frako.com](mailto:info@frako.com)

